

BREECHES

Breeches were worn in one form or another by men of all classes. The peasant wore baggy, knee-length breeches, or cross-gartered trews. The middle class men wore breeches, or more tailored, padded versions called Venetians, especially favored by sailors and soldiers. The upper class gentleman wore Venetians, slops, or tight-fitting breeches called canions under panned slops.

Peasant Breeches

Peasant breeches are the simplest types to make. You will need a man's trouser pattern of the correct size and about two yards of some homespun looking fabric. See the pattern section for suggested trouser pattern types and yardages.

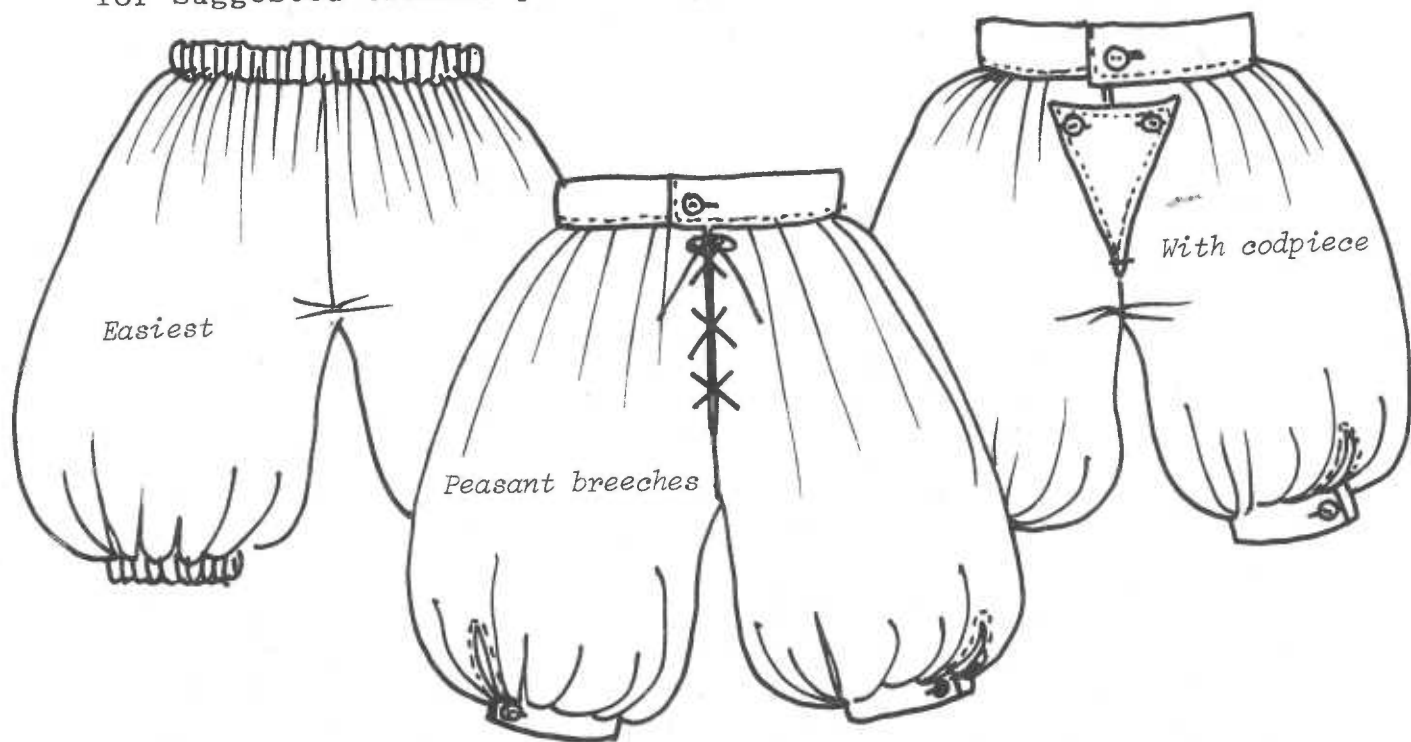

Measure the man from his waist to just above or below his knee, depending on how long you want them to be. Add 4"-6" to this measurement. Measure that distance down from the waist of the pants pattern pieces and cut off the legs at that point. If you want to reuse the pattern, just fold the legs up instead of cutting them off. If you want to have a waistband and legbands, which will look better and be more authentic, cut one paper pattern piece 8" wide and your waist measurement plus 3" long. Cut another pattern piece 4" wide and the leg measurement (above or below the knee) plus 2" long for the legband. Cut two triangles 8" across the top and 12"-14" from top edge to point. This will be the optional codpiece.

Lay out the pattern pieces as illustrated. Cut only one waistband and two legbands, if you are going to use them.

Sew the crotch seams, leaving the front seam open enough to put in your fasteners later. We suggest you use hooks and eyes or grommets for lacing. Now fold and sew the inside leg seams. For the simplest pants, turn the waist and leg edges twice for casings and insert elastic. If you are using elastic in the waistband, sew up the crotch seam all the way, before turning the top edge down.

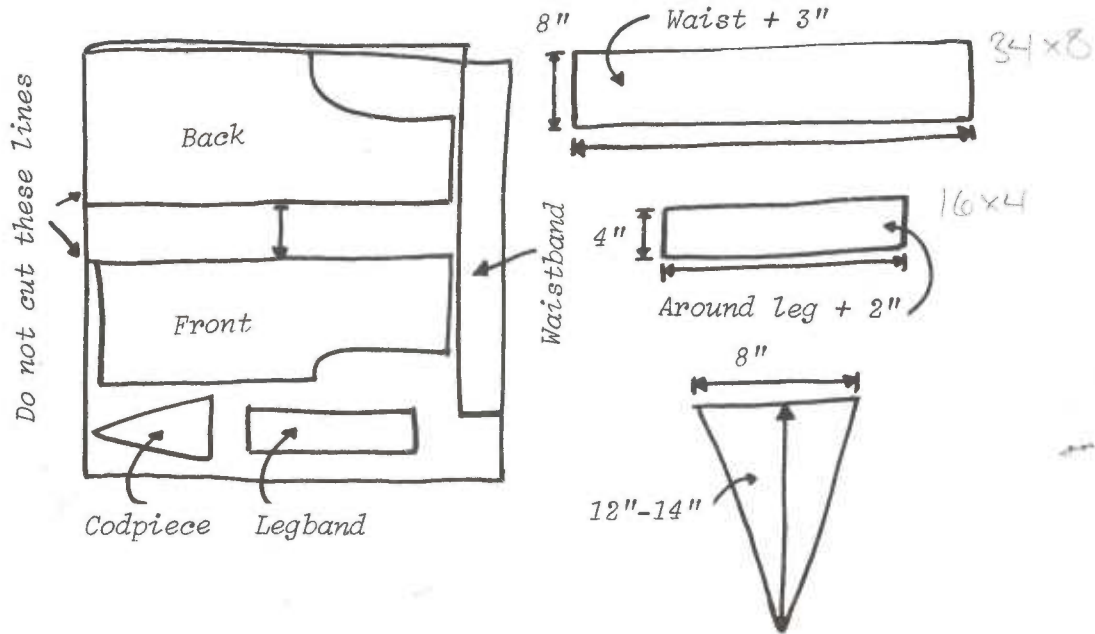

If you are using a waistband and legbands, rather than elastic, slash each leg vertically up to 4" from the bottom edge of the leg piece, halfway between the two inside leg seams. Turn and sew the slashings toward the inside. Now pleat or gather the top edge of the breeches into the waistband and finish off with flat hooks & eyes, buttons, or grommets. Then do the same for the bottom edges and the legbands.

